

Absorptive, Broadband MMIC Switch

0.01-26.5 GHz/SP4T/ SMA Female

Model: TLSP4T0.01G26.5GA

The TLSP4T0.01G26.5GA is an absorptive MMIC switch with a TTL driver that operates between 0.01 and 26.5 GHz. The SP4T switch offers 70 dB port-to-port isolation with a typical switching speed of 100 nanoseconds. The input and output connectors of the switch are SMA female.

Features:

- Ultra Wide Band: 0.01-26.5GHz
- Low Insertion Loss: 4.0 dB
- Power Handling : 25 dBm
- High Isolation
- Switch Type: Absorptive

Applications:

- Communication Systems
- Automatic Test Equipment
- Switching Network

电气特性 Electrical Characteristics:

参数 Parameter	Min	Typ	Max	单位 Units
频率范围 Frequency range	0.01-26.5			GHz
插损 Insertion Loss		4	6	dB
隔离 Isolation	60	70		dB
切换速度 Switch Speed		100		ns
输入驻波 Input VSWR		2	3	:1
输出驻波 Output VSWR		2	3	:1
耐功率 Power Handling			25	dBm
直流电压 DC Voltage		5		V DC
直流电流 DC Supply Current		20		mA
开关类型 Switch type	Absorptive			
阻抗 Impedance	50			Ohms

绝对最大值 Absolute Maximum Ratings :

描述 Description	参数 Parameter	单位 Units
供电偏置电压 Supply Bias Voltage	±5%	V
射频输入功率 RF Input Power	25	dBm
ESD灵敏度 ESD sensitivity (HBm)	Class 0, passed 150V	

机械特性 Mechanical Specifications:

描述 Description	参数 Parameter	单位 Units
输入/输出接口 Input /Output Connector	SMA Female/SMA Female	
直流控制接口 Control Bias	Solder Pin	
尺寸 Size	50.8*30*10.2	mm

外形图 Outline Drawing:

Unit:mm

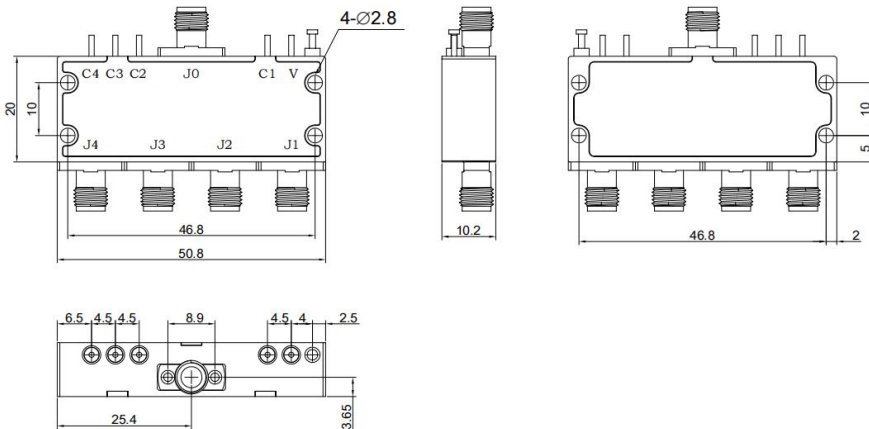

真值表 Truth Table

TTL Control Input				Signal Path State
C4	C3	C2	C1	
0	0	0	0	J0-J1
0	0	1	0	J0-J2
0	1	0	0	J0-J3
1	0	0	0	J0-J4

1. Dimensions are in mm [inches]
 2. Tolerances: Outline drawing ± 0.2 [0.008] Hole ± 0.2 [0.008]
- NOTE: ALL SPECIFICATIONS ARE SUBJECT TO CHANGE WITHOUT NOTICE AT ANY TIME

TTL Control Voltages &VDD

Stage	Bias Condition
VDD	+5V ($\pm 5\%$)
Low (0)	0 to 0.8Vdc
High (1)	+3.3 to +5.0Vdc



OBSERVE PRECAUTIONS
ELECTROSTATIC SENSITIVE
DEVICES

温度环境 Environmental Conditions:

参数 Parameter	Min	Typ	Max	单位 Units
操作温度 Operating Temperature	-10		+65	°C
存储温度 Non-operating Temperature	-45		+85	°C
相对湿度 Relative humidity		95		%
海拔 Altitude	10,000			feet
震动 Shock / Vibration(MIL-STD-810F)	25g rms (15 degree 2KHz) endurance, 1 hour per axis			
冲击 Shock(non operating)	20G for 11msc half sin wave,3 axis both directions			

订货信息 Ordering Information:

标准型号 Base Number	描述 Description	版本号 Revision
TLSP4T0.01G26.5GA	Absorptive, Broadband MMIC Switch 0.01-26.5 GHz, SP4T, SMA	Rev.1.1

典型曲线 Typical Performance Data:

Insertion Loss&VSWR vs Frequency

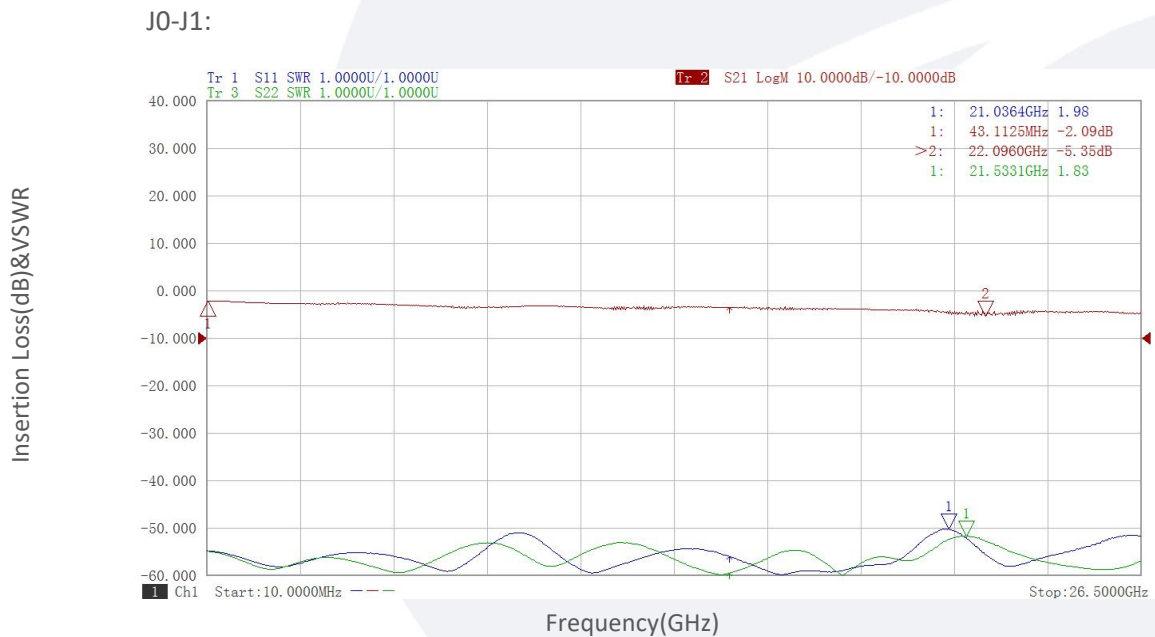

Note: Above data is for ref only, actual data may vary from unit to unit depending on operating environment and other factors like material lots etc.

典型曲线 Typical Performance Data:

Isolation vs Frequency

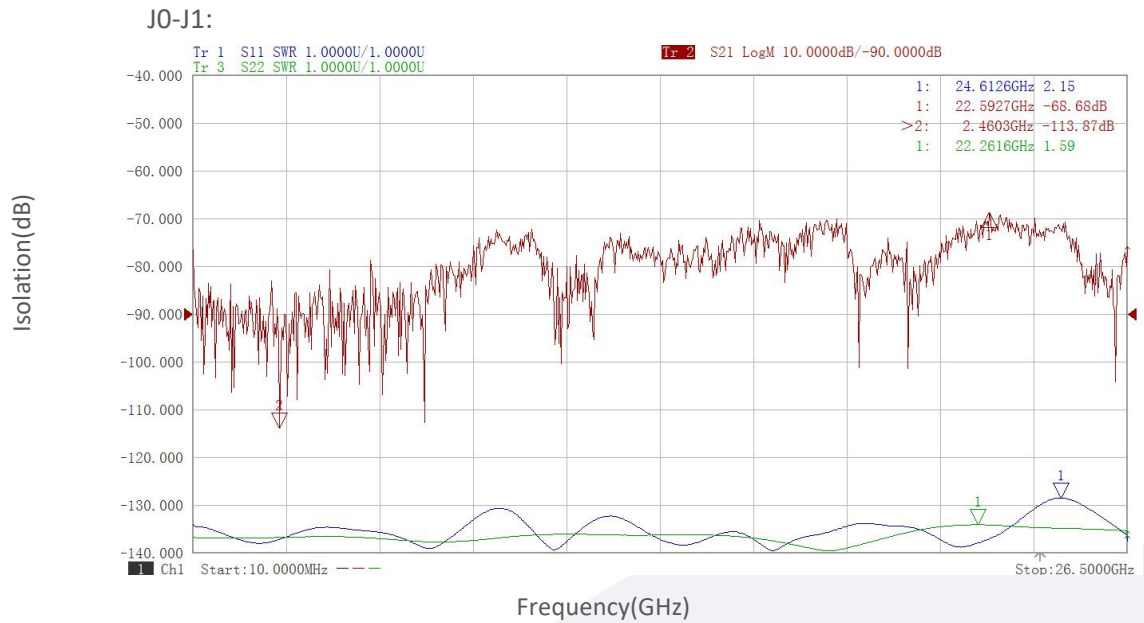

Insertion Loss & VSWR vs Frequency

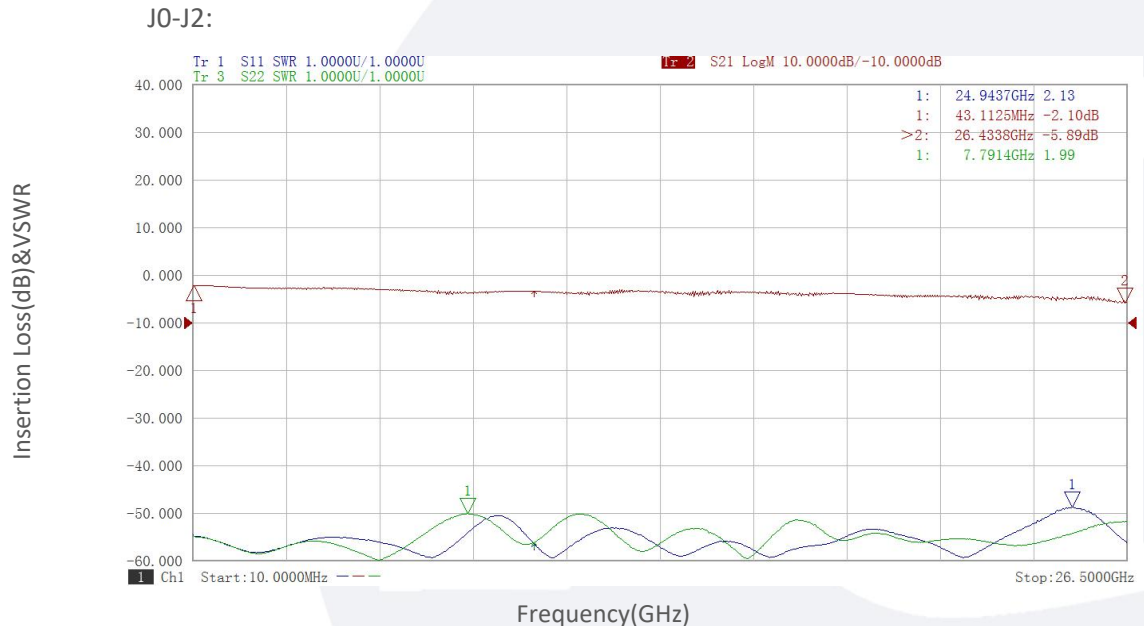

Note: Above data is for ref only, actual data may vary from unit to unit depending on operating environment and other factors like material lots etc.

典型曲线 Typical Performance Data:

Isolation vs Frequency

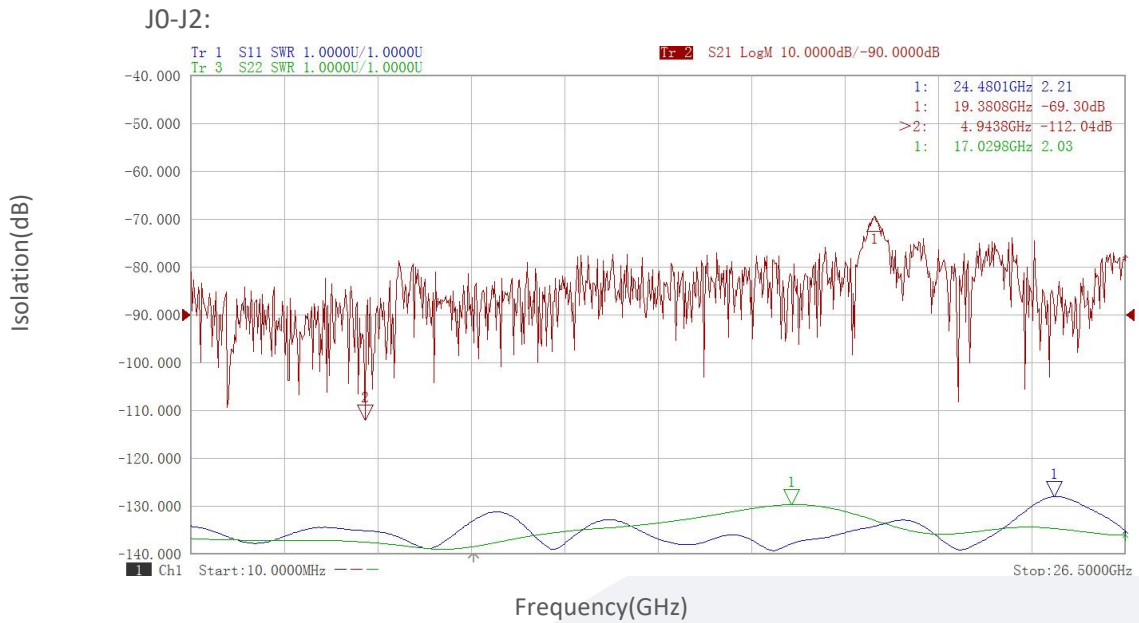

Insertion Loss & VSWR vs Frequency

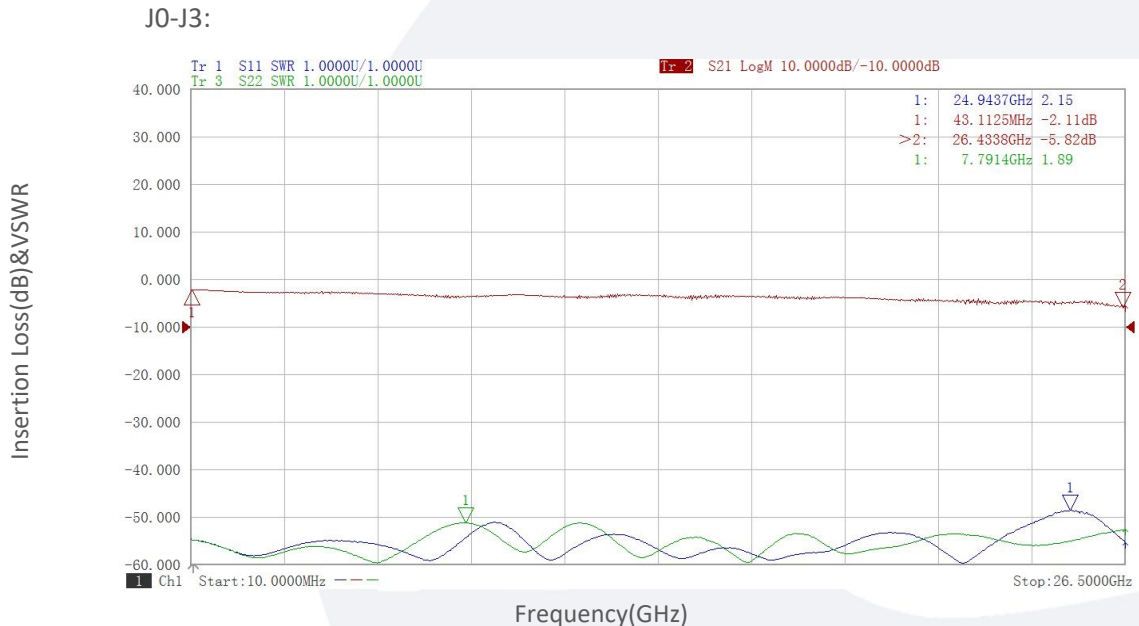

Note: Above data is for ref only, actual data may vary from unit to unit depending on operating environment and other factors like material lots etc.

典型曲线 Typical Performance Data:

Isolation vs Frequency

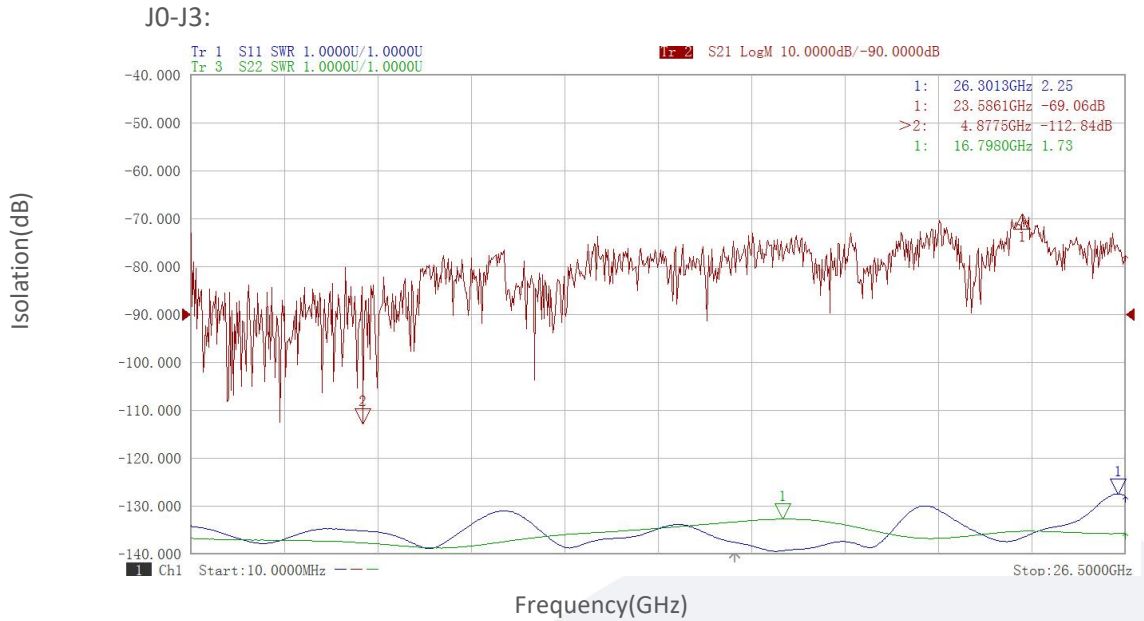

Insertion Loss & VSWR vs Frequency

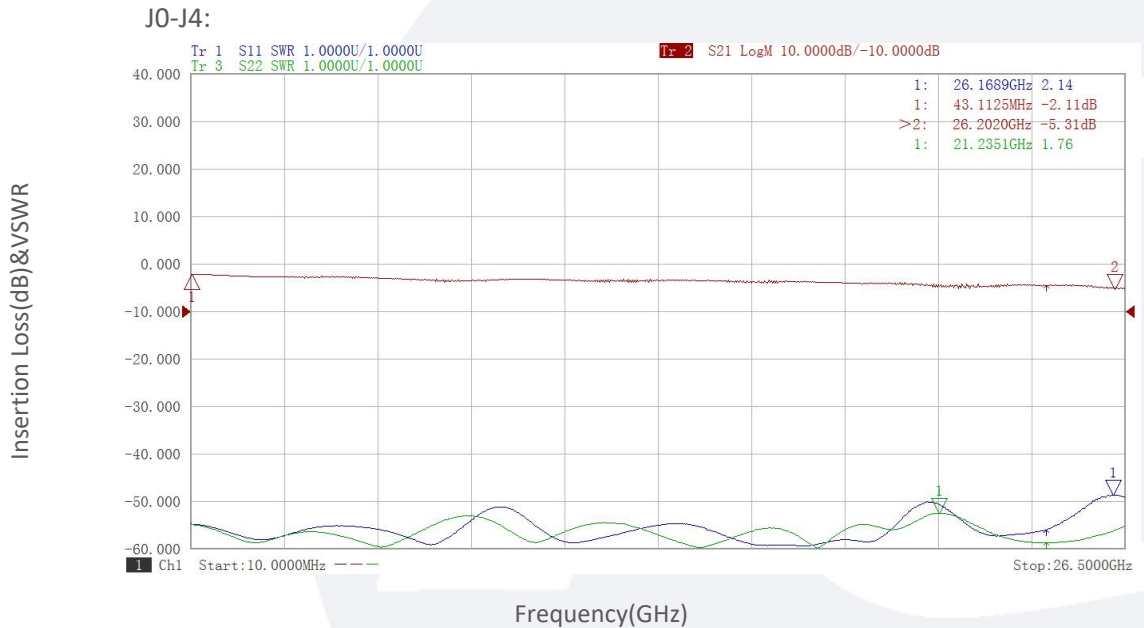

Note: Above data is for ref only, actual data may vary from unit to unit depending on operating environment and other factors like material lots etc.

典型曲线 Typical Performance Data:

Isolation vs Frequency

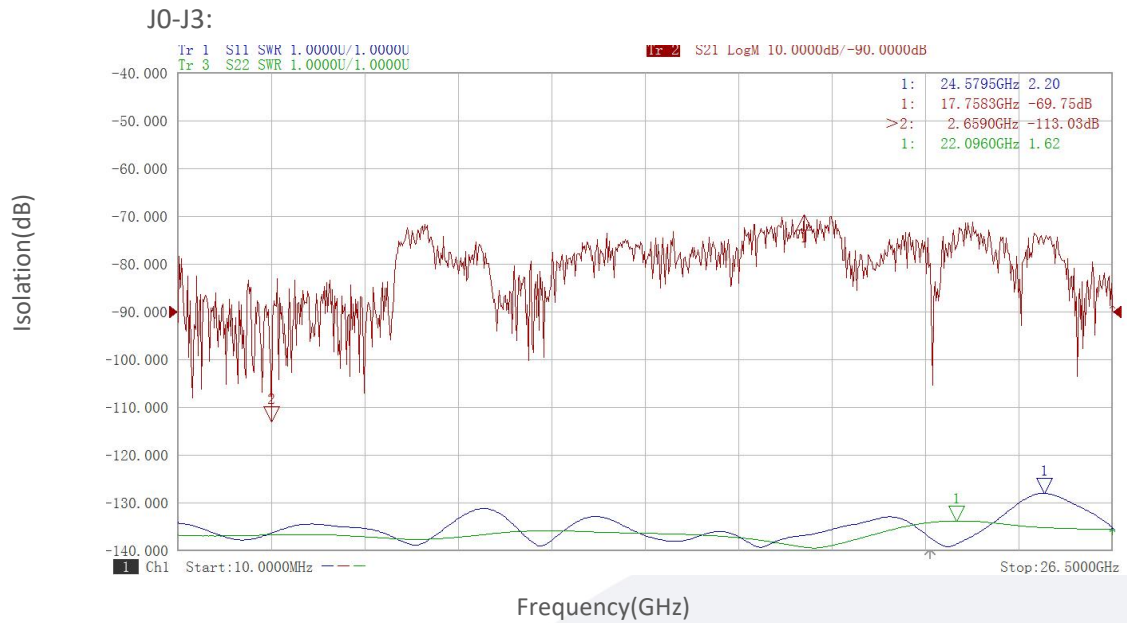

Note: Above data is for ref only, actual data may vary from unit to unit depending on operating environment and other factors like material lots etc.