

Flexible Ultra Low Loss Coax Cable Assembly

A22/1.85mm Female /2.92mm Male/DC-40 GHz

Model: A22-1.85F2.92M-L



Features:

- Max Frequency 40 GHz
- VSWR max of 1.30
- Velocity of Propagation of 82%

Applications:

- Test & Measurement equipment
- Manufacturing lab
- WAN system equipment

Cable Cross Section:

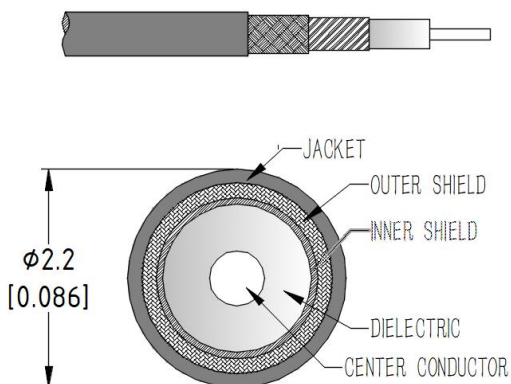

Electrical Characteristics:

Parameter	Min	Typ	Max	Units
Frequency Range	DC		40	GHz
VSWR		1.25	1.3	:1
Velocity of propagation		82%		
Shielding Effectiveness	90			dB
Capacitance			81	pF/m
Phase Stability Vs. Flexure@40GHz		±3		°
Amplitude Stability Vs. Flexure@40GHz		±0.03		dB
Phase Stability Vs. Temperature			550	PPM

Environmental And Physical Characteristics:

Description	Parameter	Units
Cable Diameter	2.2	mm
Cable Jacket	FEP	
Min. Bending Radius	11	mm
Typical Flex life	50000	
Operating Temperature	-55 to +125	°C
Storage Temperature	-55 to +165	°C

Cable Performance By Frequency

Frequency	2 GHz	4 GHz	6 GHz	8 GHz	12 GHz	18 GHz	26.5 GHz	40GHz	50 GHz	67GHz
Insertion Loss (dB/m Max)	0.91	1.30	1.60	1.86	2.31	2.87	3.54	4.44	5.03	5.93
RF Power CW (W Max.)	190	133	108	82	75	60	49	39	34	29

Connectors:

Description	Connector 1	Connector 2
Type	1.85mm Straight Female	2.92mm Straight Male
Contact Material And Plating	Beryllium Copper, Gold	Beryllium Copper, Gold
Dielectric Type	PEI	PEI
Body Material And Plating	Passivated Stainless Steel	Passivated Stainless Steel
Insertion Loss (dB Max)	$0.05 * \sqrt{f_GHz}$	$0.05 * \sqrt{f_GHz}$

Outline Drawing:

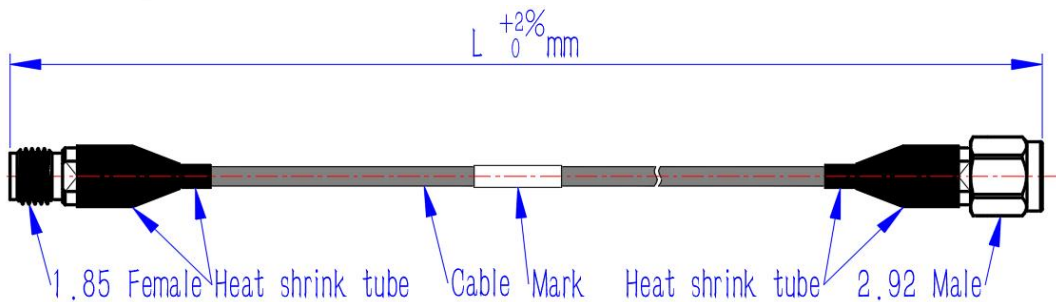

Ordering Information:

Base Number	Lenth	Armour (optional)	Phase/delay Matched (optional)
A22-1.85F2.92M	-L	-A(Black nylon woven armor)	
		-AP(PUR water proof armor)	-XXPS($\leq \pm XX$ PS)
		-AS(Stainless steel armor)	-XX°($\pm XX^\circ$)
		-AT(Transparent armor)	

Typical Performance Data:

Model:A22-1.8F2.92M-1m

Frequency	2 GHz		6 GHz		12 GHz		18 GHz		26.5 GHz		40GHz	
	Typ	Max	Typ	Max	Typ	Max	Typ	Max	Typ	Max	Typ	Max
Insertion Loss(dB)	0.98	1.05	1.73	1.85	2.48	2.66	3.08	3.29	3.80	4.05	4.76	5.07
VSWR	1.03	1.05	1.05	1.10	1.10	1.15	1.15	1.20	1.20	1.25	1.25	1.30