

Model: TMPA-050060-3625-15
Power Amplifier
50-60GHz, Gain:36 dB,Psat:25 dBm
Feature:

- Frequency Range:50-60 GHz
- Gain:36dB Typ
- Output Power Psat:25dBm Typ
- Good Power and Gain Flatness

电气特性 Electrical Specifications:

参数Parameter	Min	Typ	Max	单位Units
频率范围 Frequency range	50-60			GHz
小信号增益 Small Signal Gain		36		dB
饱和输出功率 Output Psat		25		dBm
输入驻波 Input VSWR		2		:1
输出驻波 Output VSWR		1.7		:1
直流电压 DC Voltage		+12		V DC
直流电流 DC Supply Current		500		mA

机械特性 Mechanical Specifications:

参数Parameter	指标 Value	单位Units
输入/输出接口 Input /Output Connector	WR-15/UG-385/U	
直流偏置 DC Bias	Solder Pin	
尺寸 Size	50*50*20	mm
重量 Weight	/	g

绝对最大值 Absolute Maximum Ratings:

参数Parameter	指标 Value
供电偏置电压 Supply Bias Voltage	+15V
输入功率 RF Input Power	10 dBm
ESD灵敏度 ESD sensitivity (HBm)	Class 0, passed 150V

**Available 220V System
 Benchtop Amplifier**

外形尺寸 Outline Drawing:

Unit: mm

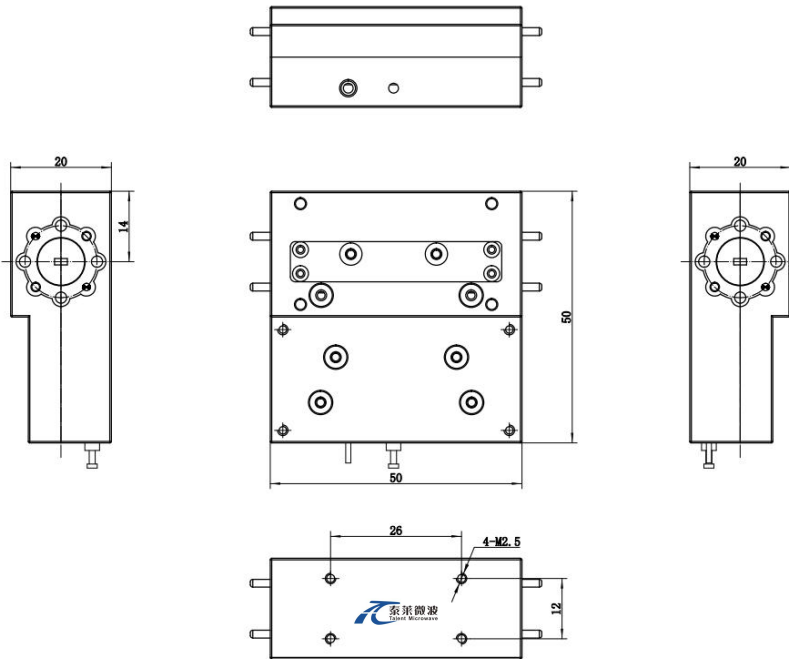

温度环境 Environmental Conditions:



OBSERVE PRECAUTIONS
ELECTROSTATIC SENSITIVE
DEVICES

参数 Parameter	Min	Typ	Max	单位 Units
操作温度 Operating Temperature	0		+65	°C
存储温度 Non-operating Temperature	-55		+125	°C
相对湿度 Relative humidity		95		%
海拔 Altitude	50,000			feet
震动 Shock / Vibration(MIL-STD-810F)	25g rms (15 degree 2KHz) endurance, 1 hour per axis			
冲击 Shock(non operating)	20G for 11msc half sin wave,3 axis both directions			

订货信息 Ordering Information:

标准型号 Part Number	描述 Description	版本号 Revision
TMPA-050060-3625-15	Power Amplifier,50-60 GHz, Gain:36dB Typ,Psat:25dBm Typ,+12V DC,WR-15	Rev.1.1

典型曲线 Typical Performance Data:

Gain vs Frequency

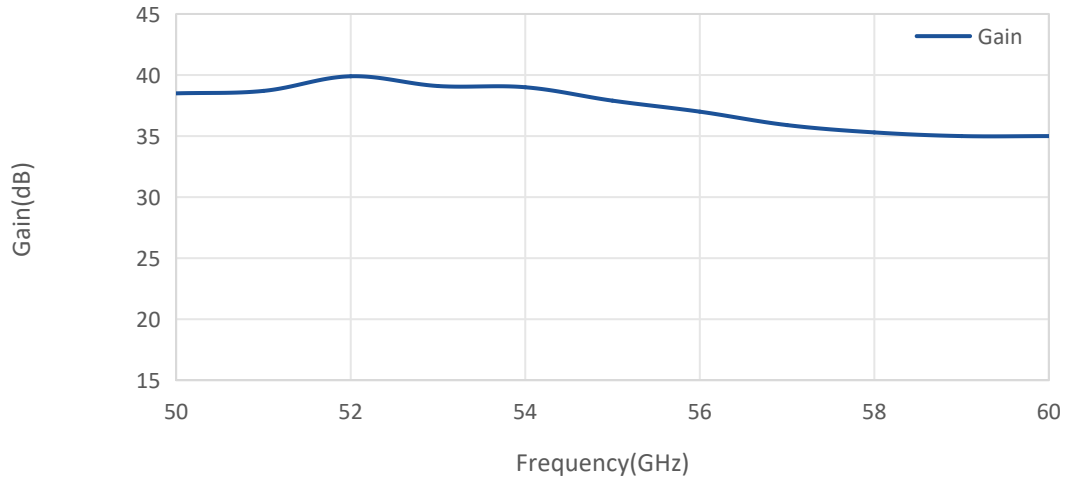

VSWR vs Frequency

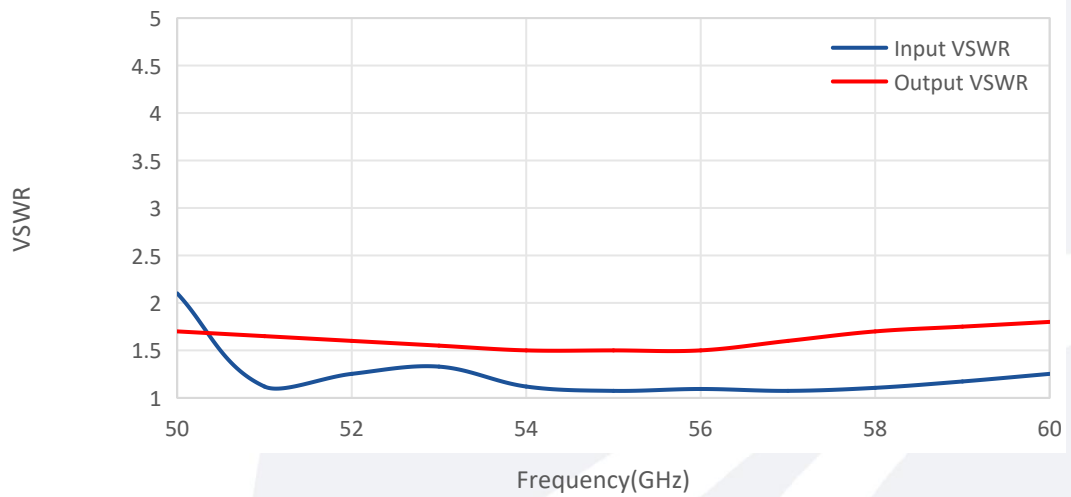

Psat vs Frequency

