

**Model: TMLA-075110-3542-10**
**Low Noise Amplifier**  
**75-110GHz, NF:4.2 dB, Gain:35 dB**
**Feature:**

- Ultra Wide Band: 75-110 GHz
- Gain:35dB Typ
- Noise Figure:4.2dB Typ
- Unconditional stability

**电气特性 Electrical Specifications:**

参数Parameter	Min	Typ	Max	单位Units
频率范围 Frequency range	75		110	GHz
增益 Gain		35		dB
增益平坦度 Gain Flatness		±4		dB
噪声系数 Noise Figure		4.2		dB
输出功率1dB压缩点 Output P1dB		8		dBm
输入驻波 Input VSWR		2.5		:1
直流电压 DC Voltage		+12		V DC
直流供电 DC power supply		70		mA

**机械特性 Mechanical Specifications:**

参数Parameter	指标 Value	单位Units
输入接口 Input Connector	WR-10/ UG-387/U	
输出接口 Output Connector	WR-10/ UG-387/U	
供电引脚 Power Supply Pin	Solder Pin	
尺寸 Size	39*30*23	mm

**绝对最大值 Absolute Maximum Ratings:**

参数Parameter	指标 Value
供电偏置电压 Supply Bias Voltage	+15 V
输入功率 RF Input Power	0dBm
ESD灵敏度 ESD sensitivity (HBm)	Class 0, passed 150V

**Available 220V System  
 Benchtop Amplifier**

外形尺寸 Outline Drawing:

Unit: mm

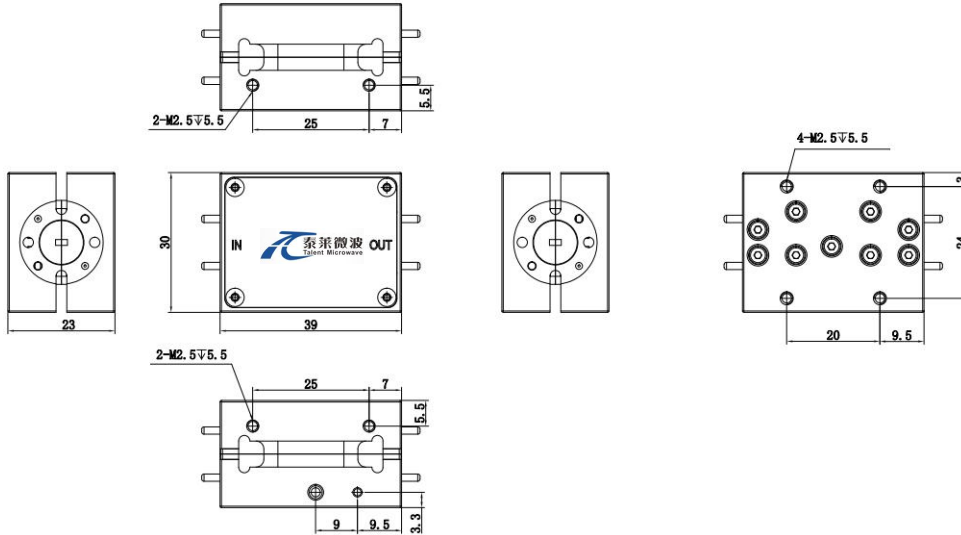

温度环境 Environmental Conditions:



OBSERVE PRECAUTIONS  
ELECTROSTATIC SENSITIVE  
DEVICES

参数Parameter	Min	Typ	Max	单位Units
操作温度 Operating Temperature	0		+65	°C
存储温度 Non-operating Temperature	-45		+125	°C
相对湿度 Relative humidity		95		%
海拔 Altitude	50,000			feet
震动 Shock / Vibration(MIL-STD-810F)	25g rms (15 degree 2KHz) endurance, 1 hour per axis			
冲击 Shock(non operating)	20G for 11msc half sin wave,3 axis both directions			

订货信息 Ordering Information:

标准型号 Part Number	描述 Description	版本号Revision
TMLA-075110-3542-10	Low Noise Amplifier,75-110GHz, Noise Figure:4.2dB, Gain:35dB,+12V DC,WR-10	Rev.1.1

典型曲线 Typical Performance Data:

Gain vs Frequency

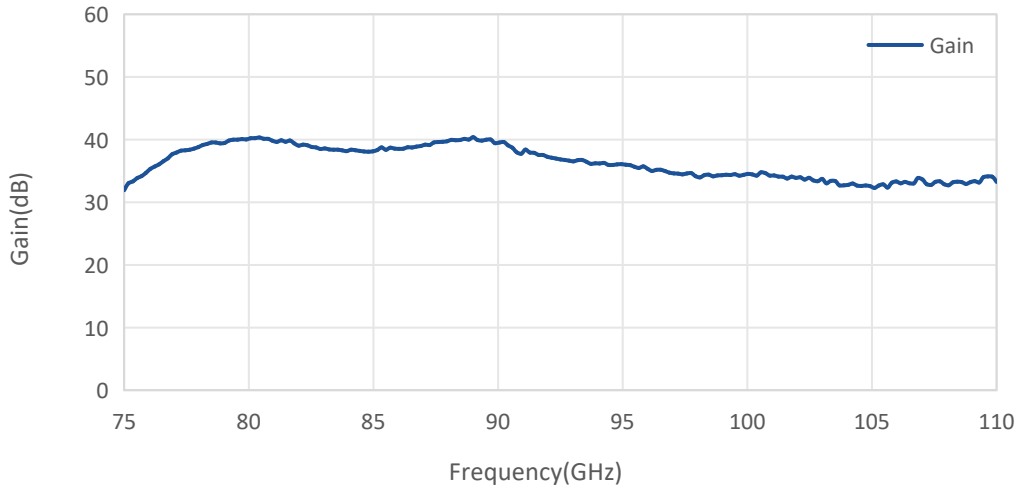

Noise Figure vs Frequency

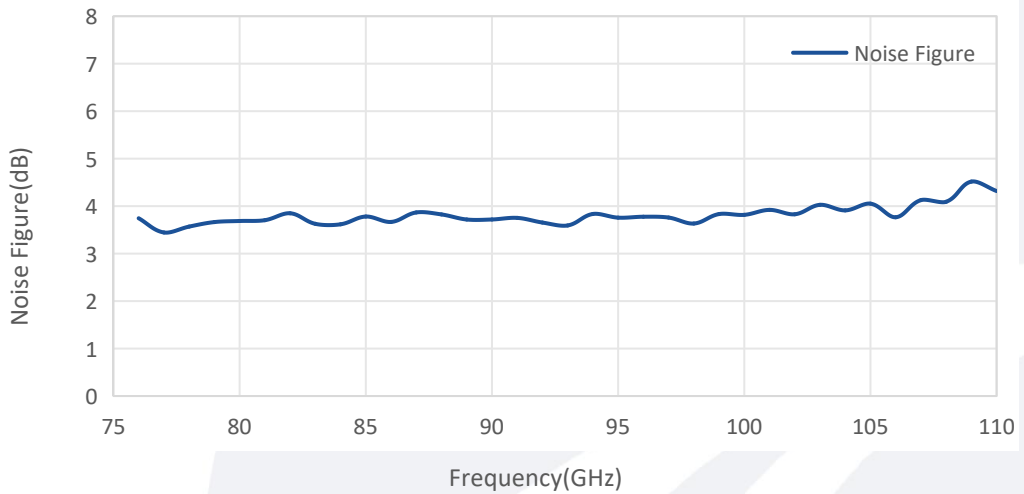

Input VSWR vs Frequency

