

Model: TLSP4T1G18GA
**Absorption, Broadband PIN Switch
 1-18GHz, SP4T, SMA**
Feature:

- Ultra Wide Band: 1-18 GHz
- Low Insertion Loss: 3.5 dB
- Power Handling : 30dBm
- High Isolation
- Switch Type: Absorption

电气特性 Electrical:

参数Parameter	Min.	Typ.	Max.	单位Units
频率范围 Frequency range	1-18			GHz
插损 Insertion Loss		2.5	3.5	dB
隔离 Isolation	60	70		dB
切换速度 Switch Speed			100	ns
输入驻波 Input VSWR		1.5	2.0	:1
输出驻波 Output VSWR		1.5	2.0	:1
最大输入功率 RF Input Power			30	dBm
直流电压 DC Voltage		+5/-5		V DC
直流电流 DC Supply Current		160/50		mA
阻抗 Impedance	50			Ohms

机械特性 Mechanical :

参数Parameter	指标 Value	单位Units
输入输出接口 Input /Output Connector	SMA Female	
直流控制接口 Control Bias	PIN	
尺寸 Size	52*18*12.5	mm
重量 Weight	TBD	g

绝对最大值 Absolute Maximum Ratings:

参数Parameter	指标 Value
供电偏置电压 Supply Bias Voltage	+/-5%
输入功率 RF Input Power	30 dBm
ESD灵敏度 ESD sensitivity (HBm)	Class 0, passed 150V

外形尺寸 Outline Drawing:

Unit: mm(Inches)

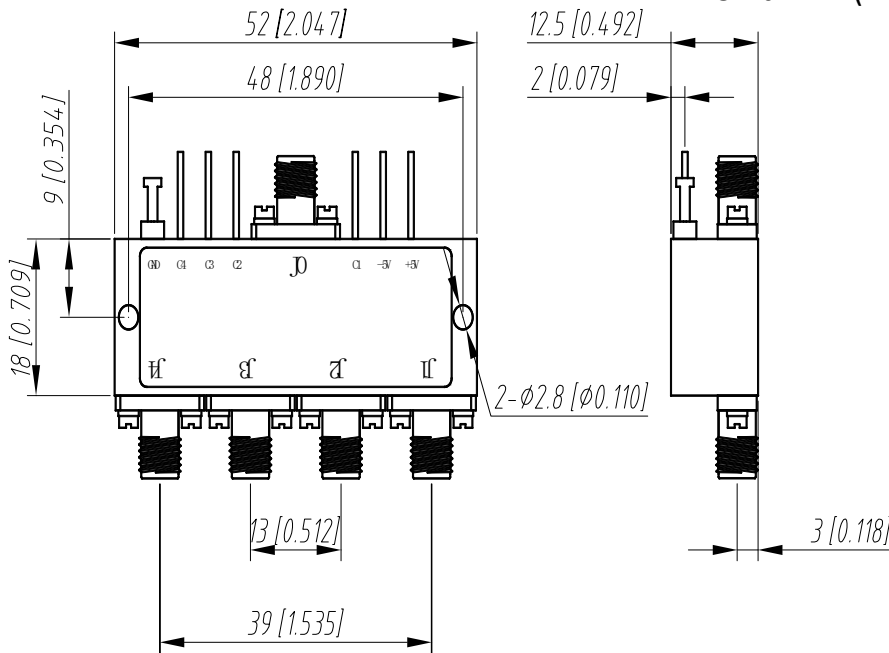

真值表 Truth Table				
TTL Control Input				Signal Path State
C4	C3	C2	C1	
0	0	0	0	NC
1	1	1	0	J0-J1
1	1	0	1	J0-J2
1	0	1	1	J0-J3
0	1	1	1	J0-J4
1	1	1	1	OFF



OBSERVE PRECAUTIONS
ELECTROSTATIC SENSITIVE
DEVICES

温度环境 Environmental Conditions:

参数 Parameter	Min.	Typ.	Max.	单位 Units
操作温度 Operating Temperature	-45		+85	°C
存储温度 Non-operating Temperature	-55		+125	°C
相对湿度 Relative humidity		95		%
海拔 Altitude	50,000			feet
震动 Shock / Vibration(MIL-STD-810F)	25g rms (15 degree 2KHz) endurance, 1 hour per axis			
冲击 Shock(non operating)	20G for 11msc half sin wave,3 axis both directions			

订货信息 Ordering Information:

标准型号 Part Number	描述 Description	版本号 Revision
TLSP4T1G18GA	Absorption, Broadband PIN Switch 1-18GHz, SP4T, SMA	Rev.1.1