

**Part No.: RS3DC30-S**

**Power Splitter/Combiner 3 Way SMA 50Ω DC to 3 GHz**

**电气特性 Electrical:**

工作频率 Frequency Range: DC-3GHz  
 插入损耗 Insertion Loss:  $\leq 9.5\text{dB} \pm 0.7\text{dB}$   
 驻波 VSWR:  $\leq 1.25 : 1$   
 幅度平衡 Amplitude Balance:  $\leq \pm 0.7\text{dB}$   
 耐功率 Power Handling: 1 Watt  
 阻抗 Impedance: 50 OHMS

**机械特性 Mechanical:**

温度范围 Temperature Range:  $-55^{\circ}\text{C} - +85^{\circ}\text{C}$   
 接口 Connectors: SMA-Female  
 相对湿度 Relative Humidity: 0 ~ 90%

**外形尺寸 Outline Drawing:**

Unit: mm

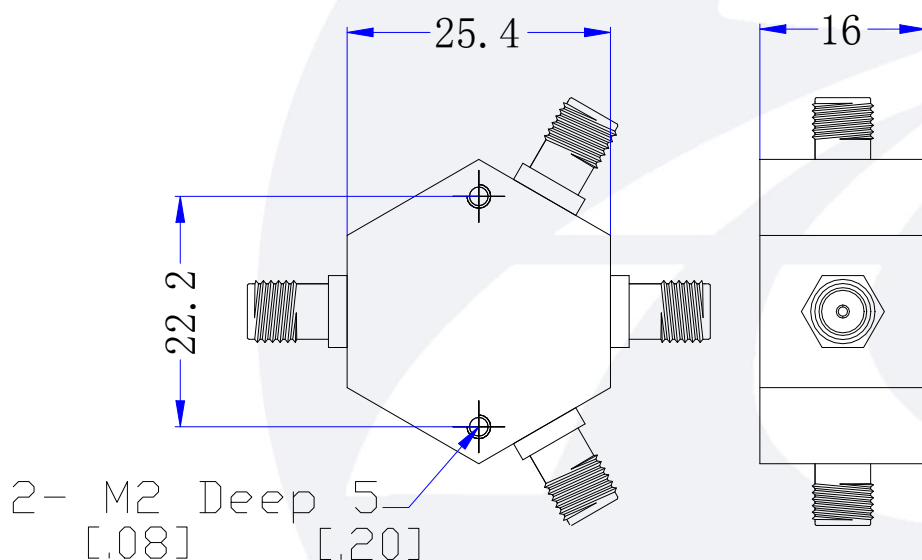



Trc1 **S11** SWR 100 mU/ Ref1 U Cal 1

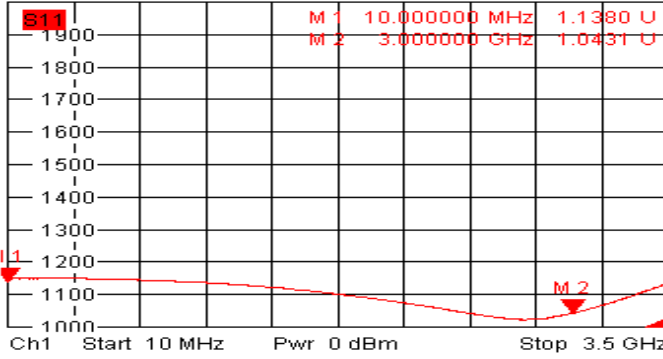

Trc2 **S21** Phase 5° / Ref 0° Cal Math 2  
Mem5[Trc2] **S21** Phase 5° / Ref 0° Invisible

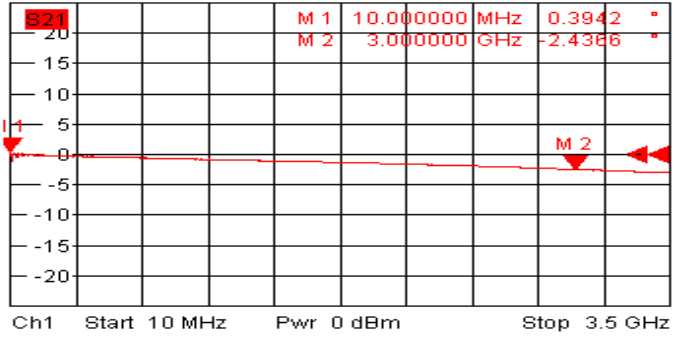

Trc3 **S21** dB Mag 1 dB / Ref -9 dB Cal 3  
Mem6[Trc3] **S21** dB Mag 1 dB / Ref -9 dB

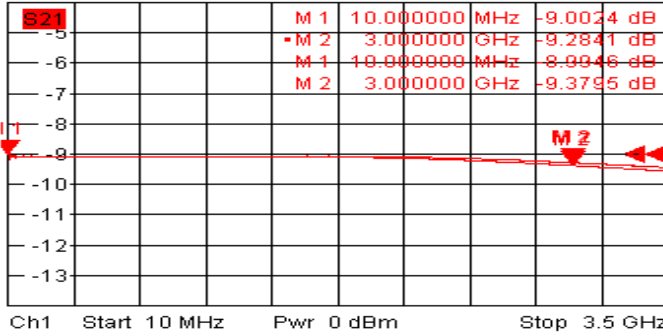

Trc4 **S22** SWR 100 mU/ Ref1 U Cal 4

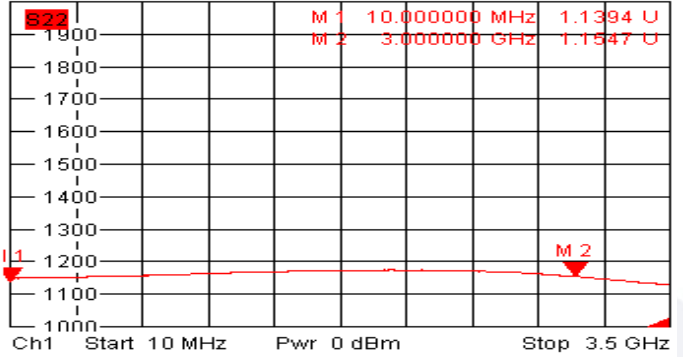

7/18/2018, 10:57 AM